

Yorktown Porch Play Floor

Creative Playthings®

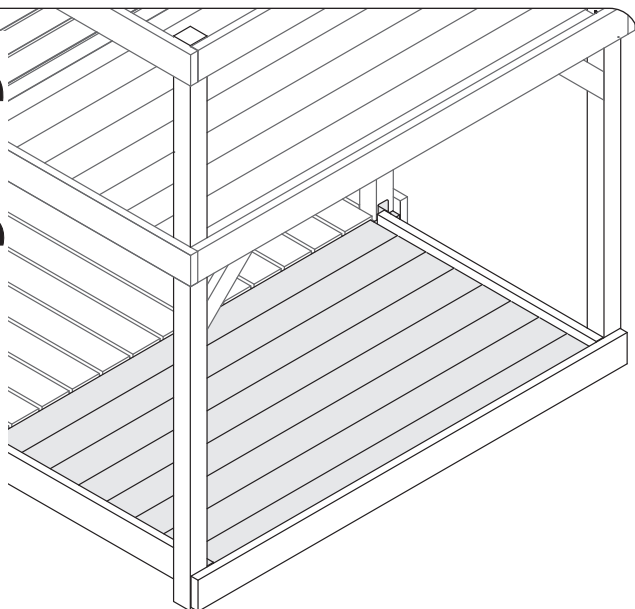

SPECIAL NOTES:

The porch play floor is designed to be used in conjunction with the main tower play floor, sometimes called the Lexington play floor.

If the Yorktown Play Walls are to be used, install this Play Floor Before installing the Play Walls. See the owner's manual for the Yorktown gym for additional safety information.

Parts:

63063-101 Yorktown Play Floor



A 1 35477-102 Floor Transition 2 x 4 x 83-1/4"



B 8 35479-102 Floor Board 5/4 x 6 x 74-1/8"



C 4 35480-102 Porch Stringer 2 x 3 x 42-3/4"

50491-701 Hardware

- 16 12017-206 Flat Washer 5/16"
- 6 12002-206 Lock Washer 5/16"
- 6 17001-104 Weld Nut 5/16
- 8 17020-115 Deck Screw #10 x 1-5/8"
- 64 17020-107 Deck Screw #10 x 2"
- 2 17003-611 Hex Bolt 5/16 x 1-1/2"
- 2 17003-1411 Hex Bolt 5/16 x 3-1/2"
- 2 17003-1611 Hex Bolt 5/16 x 4"
- 6 17036-1402 Lag Screw 5/16 x 3-1/2"
- 4 17036-2202 Lag Screw 5/16 x 5-1/2"
- 2 14161-400 Access Bracket

All hardware on this set is specially coated for corrosion resistance. If non-Creative Playthings hardware is used, it must be galvanized or stainless steel.

Hardware



Deck Screw - #10 x 2"

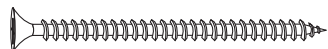

Deck Screw - #10 x 1-5/8"

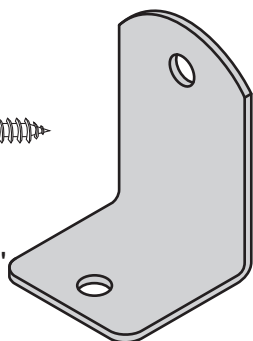

Access. Bracket
(Not to Scale)



Lag Screw - 5/16 x 3-1/2"



Lag Screw - 5/16 x 5-1/2"

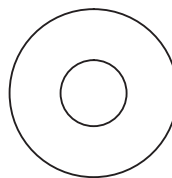

Flat Washer

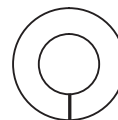

Lock Washer

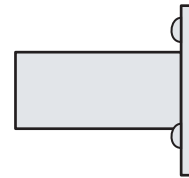

Weld Nut

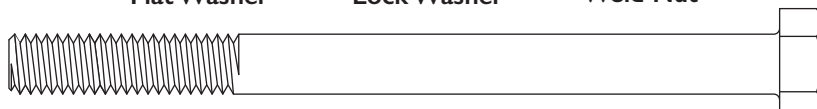

Hex Bolt - 5/16 x 4"

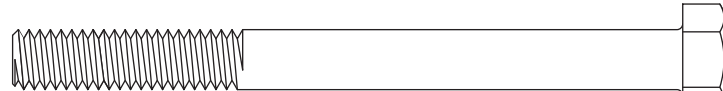

Hex Bolt - 5/16 x 3-1/2"



Hex Bolt - 5/16 x 1-1/2"

STEP ONE – Preparation

Using a putty knife or other flat blade, carefully remove the hole caps covering the central holes on the sandbox front of the porch section of the Yorktown gym. Save the hole caps for later use.

Drill 3/8" diameter holes through the center of the 1" counter-bores in the positions shown at right.

Remove the Sandbox Center, it won't be needed. Remove the Sandbox Back boards at each end of the porch base. They will be reinstalled. Save all fasteners for later use.

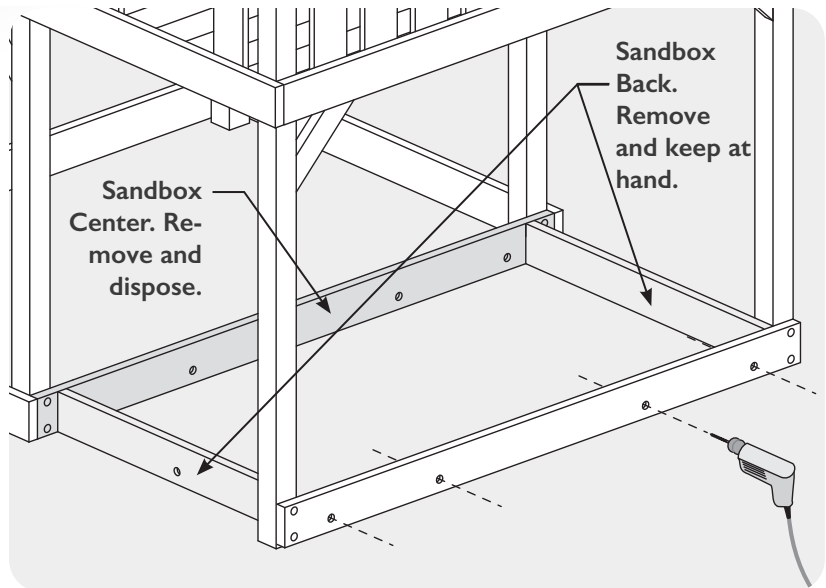

STEP TWO – Install Transition

Fasten the Floor Transition (A) to each middle post through the bottom hole using 5/16 x 4" Hex Bolt assemblies as shown.

A Hex bolt assembly consists of a Hex Bolt, Lock Washer, Flat Washer, and Weld Nut.

Align the transition so the holes at the end of the part are closest to the bottom edge.

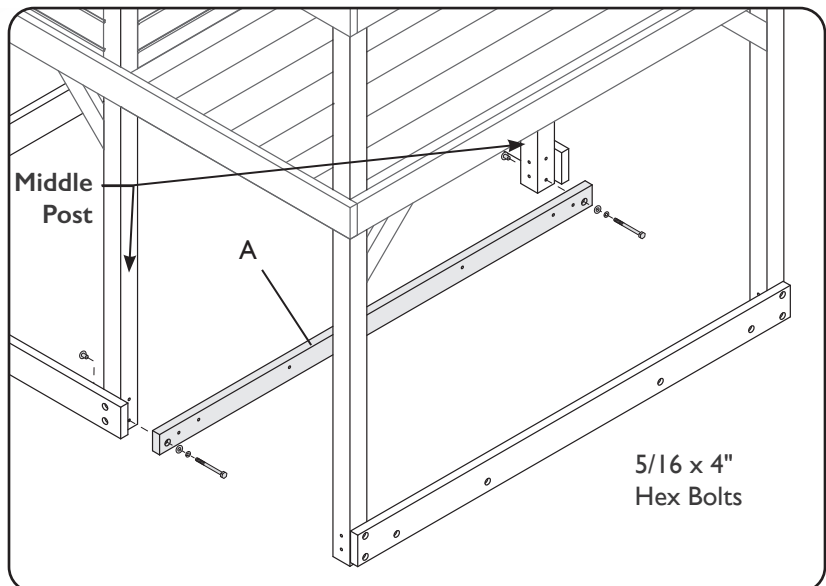

STEP THREE – Reinstall Sandbox

Restore the Sandbox Backs to the original positions using the original hardware. Please note: there is only a place for one lag screw to secure the end of each part.

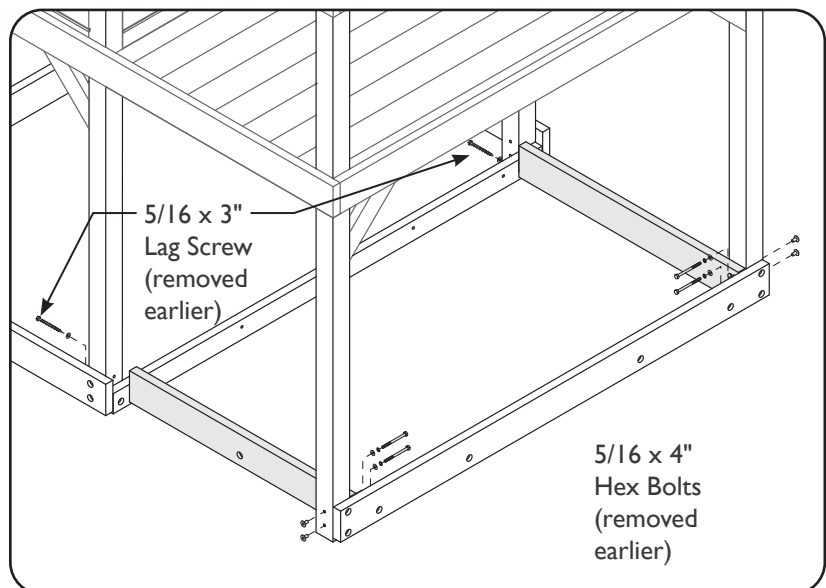

STEP FOUR – Brackets

Hold an Access Bracket against a middle post aligned with the open hole. Mark the position of the other hole in the bracket on the adjacent Sandbox Back.

Drill a 3/8" diameter hole through the board at the mark. Secure the Bracket to the post using a 5/16 x 3" Hex Bolt Assembly. Secure the Bracket to the Sandbox Back using one 5/16 x 1-1/2" Hex Bolt Assembly.

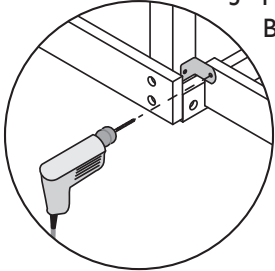

Repeat with the other Bracket at the other side of the gym.

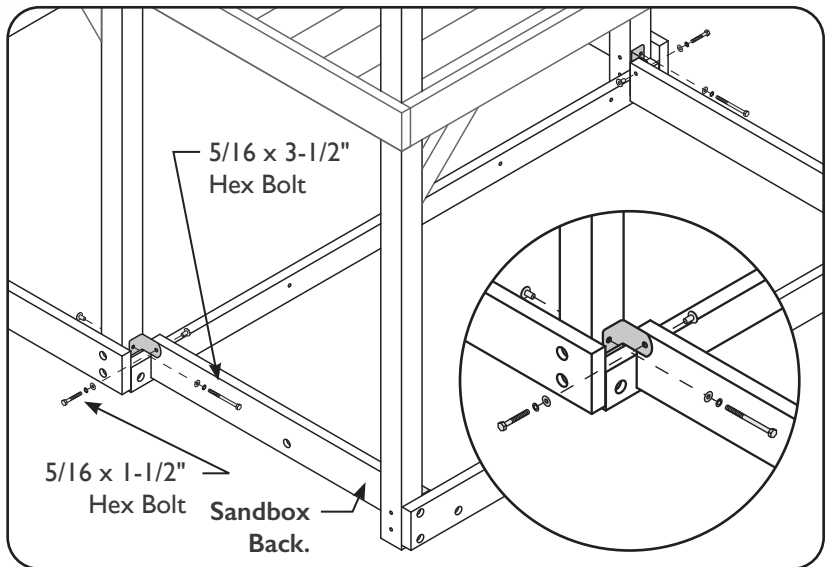

STEP FIVE – Stringers & Cleat

Locate one Cleat from the Lexington Play Floor box.

Secure the four Porch Stringers (C) between the Transition and the Sandbox front using 5/16 x 3" Lag Screws with flat washers across the front.

Use the included 5/16 x 5-1/2" Lag Screws and Flat Washers to fasten the Lexington Floor Cleat through the Transition into the Porch Stringers.

If the porch play floor is to be installed without the adjacent tower play floor, use 5/16 x 3-1/2" Lag Screws in place of the 5/16 x 5-1/2" Lag Screws. (These extra 5/16" x 3-1/2" Lag Screws are not included.)

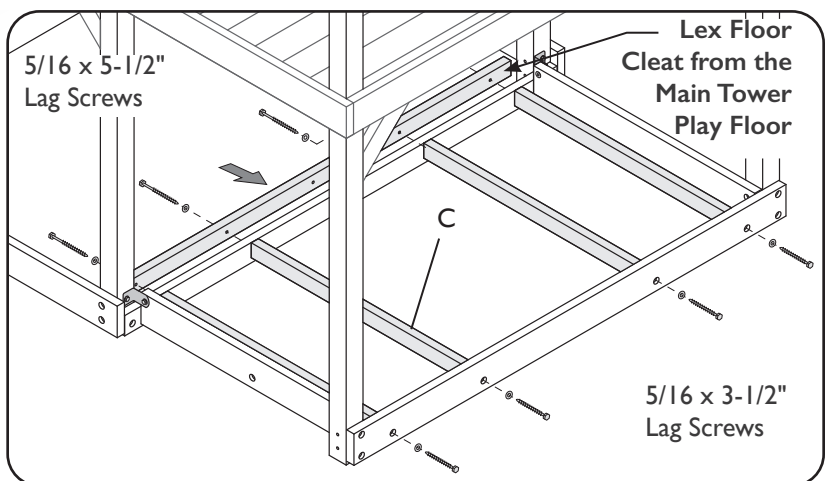

STEP SIX – Deck Boards

Set one Floor Board (B) atop the Transition with the edge of the Floor Board aligned with the edge of the Transition.

Evenly space the rest of the Floor Boards between the first board and the Sandbox End at the front of the tower. Secure each Floor Board using eight #10 x 2" Deck Screws. Use #10 x 1-5/8" Deck Screws in the places the screws might encounter the Lag Screws at the end of the Porch Stringers.

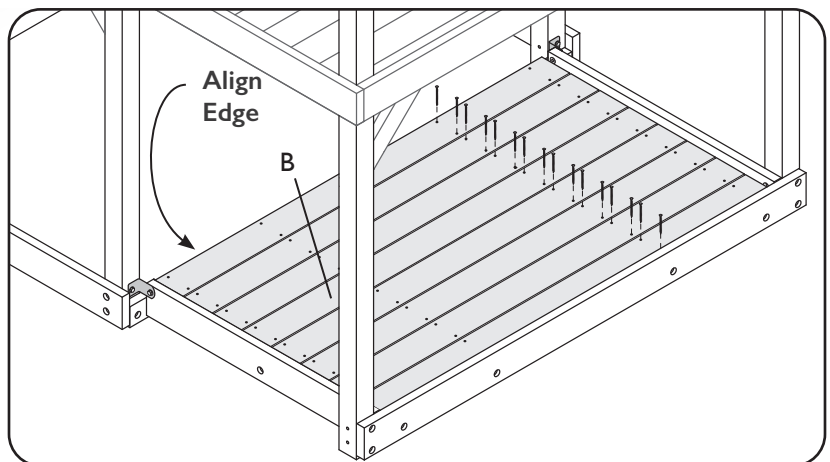

STEP SEVEN – Hole Caps

Gather the Hole Caps removed in step one. Re-insert the Hole Caps into the accessible counter-bored holes to cover the hardware.

