

Creative Playthings®

MODEL# SC 910-800Q
ASSEMBLY MANUAL

LEXINGTON PLAY FLOOR

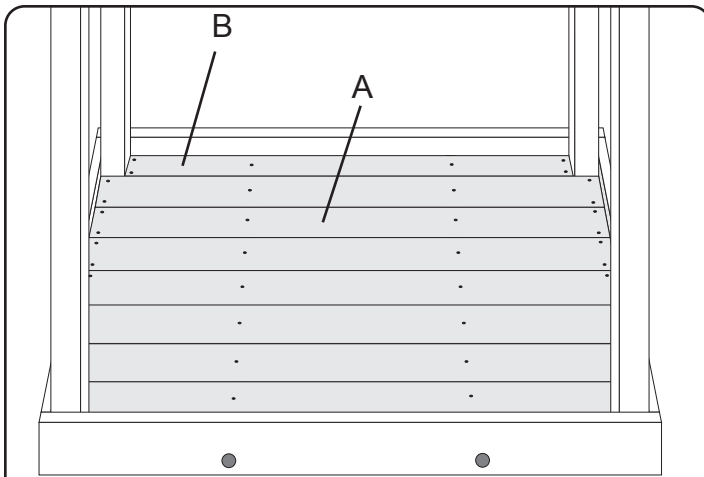

All hardware on this set is specially coated for corrosion resistance. If non-Creative Playthings hardware is used, it MUST be galvanized or stainless steel.

Special Notes:

- If also installing a Play Wall, install the Play Floor first. The Play Wall Slats rest on the Play Floor.
- Sandbox Seats must be removed. They will not be used.
- Install the Play Floor before installing a Picnic Table.

Tools Required:

- 1/2" Socket and Wrench
- Electric Drill with a 3/8" Drill Bit
- Screwdriver or Driver Tip for Electric Drill

Review the original Lexington Assembly Instructions and Owners Manual before assembly for maintenance and safety instructions.

COMPONENTS

	A	14	31806-102	Platform Board 5/4 x 6 x 56-1/8"
	B	2	31814-102	Narrow Plat. Board 5/4 x 4 x 49-3/4"
	C	2	31530-102	Cleat 2 x 3 x 76-1/4"
	D	2	31529-102	Stringer 2 x 3 x 83-1/2"
	E	4	33504-101	Corner Support 2x4x3-1/4"
				Hex Bolt
				Hole Cap
				Weld Nut
				Lag Screw
				Lock Washer
				Flat Washer
				Screw
1	50123-710	Hardware, Lexington Play Floor		
8	17001-105	Weld Nut 5/16"		
8	12017-206	Lock Washer 5/16"		
12	12002-206	Flat Washer 5/16"		
8	17003-811	Hex Bolt 5/16 x 2"		
4	17003-2211	Hex Bolt 5/16 x 5-1/2"		
4	17036-1002	Lag Screw 5/16 x 2-1/2"		
104	17020-107	Screw #10 x 2"		

STEP 1 – Drill Holes, Install Stringers:

Drill a 3/8" Diameter hole in the center of the counter-bores in the Sandbox Sides and Sandbox Ends. Drill two holes in each of the Sandbox Ends and four holes in each of the Sandbox Sides.

Fasten the two Platform Stringers (D) between the Sandbox Ends using two 5/16 x 2-1/2" Lag Screws and Flat Washers each.

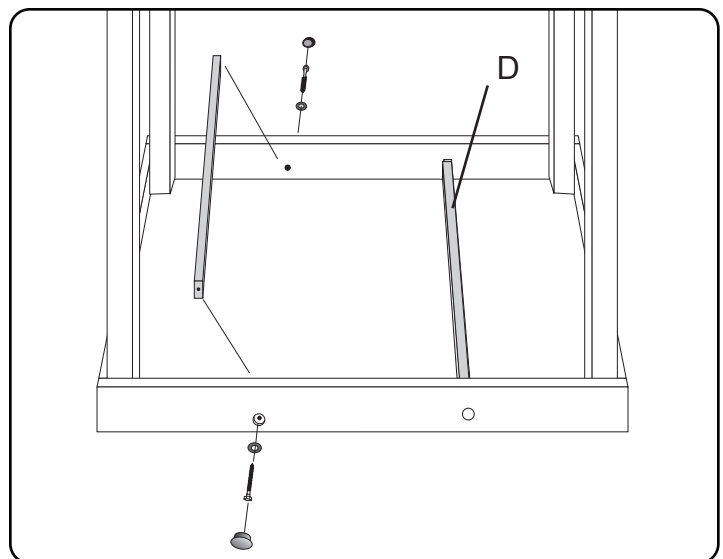

ASSEMBLY INSTRUCTIONS

STEP 2 – Platform Cleats:

Fasten a Platform Cleat (C) to each of the Sandbox Sides using three 5/16 x 2" Hex Bolt Assemblies* in each Platform Cleat. The top edges of the Platform Cleats and Platform Stringers must align.

* A Hex Bolt Assembly consists of one Hex Bolt, one Lock Washer, one Flat Washer, and one Weld Nut.

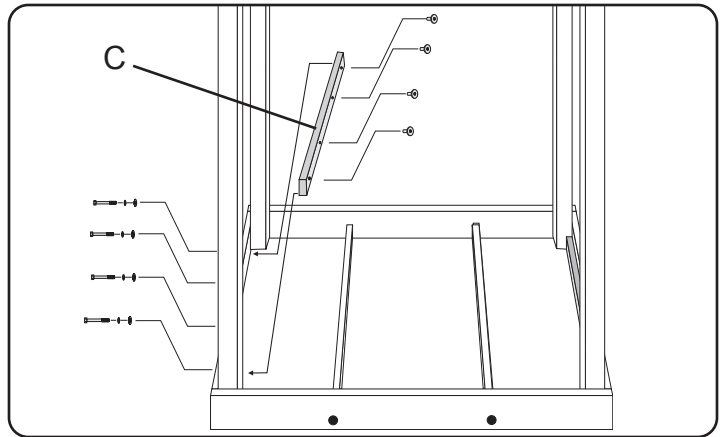

STEP 3 – Corner Supports:

Remove the Hex Bolt, Washers, and Weld Nut from the lower hole in one Corner Post in the position shown. Use a 5/16 x 5-1/2" Hex Bolt to secure the Corner Support (E) to the Corner Post. Re-use the Washers and Weld Nut.

Make sure the top of the Corner Support is even with the top of the Stringers and Cleats.

Repeat, fastening the three remaining Corner Supports on the other Corner Posts.

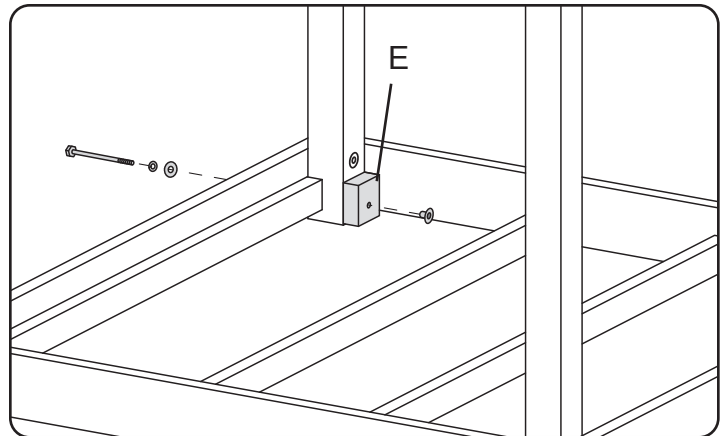

STEP 4 – Platform Boards:

Place each of the Narrow Platform Boards (B) on the Platform Stringers and tight against the Sandbox Ends. Fasten each Narrow Platform Board to the Platform Stringers using six #8 x 1-5/8" Screws.

Place the Platform Boards (A) on the Platform Stringers and Platform Cleats. Evenly space the Platform Boards between the Narrow Platform Boards and fasten them with six #10 x 2" Screws.

Replace all Hole Caps.

